



Master Kitchen

Forno elettrico da incasso

Manuale d'installazione

MODELLO: MKO 82/12 MS XS



RINGRAZIAMENTI

Grazie per aver acquistato il nostro prodotto. Speriamo che le numerose funzioni e i benefici forniti siano di suo gradimento. Prima di usare questo prodotto legga attentamente l'intero manuale di istruzioni. Lo conservi in un luogo sicuro per consultazioni future. Si assicuri che anche le altre persone che utilizzano questo prodotto leggano queste istruzioni.

ATTENZIONE

- Al momento della prima accensione, il forno può rilasciare un odore sgradevole a causa del componente adesivo usato sui pannelli isolanti all'interno dello stesso.
Riscaldare il prodotto nuovo vuoto con la funzione di cottura Tradizionale, 250 °C, 90 minuti per pulire le impurità oleose all'interno dello stesso.
- Durante il primo utilizzo, è del tutto normale che ci siano odori e un leggero fumo. In tal caso, attendere che il cattivo odore scompaia prima di mettere il cibo.
- L'elettrodomestico e le sue parti accessibili si surriscaldano durante l'uso: evitare di toccarli. Tenerlo fuori dalla portata dei bambini di età inferiore a 8 anni a meno che non siano costantemente sorvegliati.
- Se la superficie presenta delle crepe, spegnere l'elettrodomestico per evitare potenziali scosse elettriche.
- Questo elettrodomestico può essere usato da

bambini dagli 8 anni in su e da persone con capacità fisiche, sensoriali e mentali ridotte o con mancanza di esperienza e conoscenza se supervisionati o se hanno ricevuto le istruzioni relative all'uso sicuro dello stesso e capito i potenziali rischi. I bambini non devono giocare con l'elettrodomestico. La pulizia e la manutenzione non devono essere effettuate dai bambini senza supervisione.

- Durante l'uso, l'elettrodomestico si surriscalda. Evitare di toccare gli elementi caldi all'interno del forno.
- Non permettere ai bambini di avvicinarsi al forno in funzione, soprattutto quando la funzione grill è accesa.
- Assicurarsi che l'elettrodomestico sia spento prima di sostituire la lampadina per evitare potenziali scosse elettriche.
- Le spine devono essere incorporate nel cablaggio fisso secondo le specifiche di cablaggio.
- Vietare ai bambini di giocare con l'elettrodomestico.
- Questo elettrodomestico non è destinato all'uso da parte di persone (compresi i bambini) con capacità fisiche, sensoriali o mentali ridotte o con mancanza di esperienza a meno che non siano supervisionate o abbiano ricevuto le istruzioni relative all'uso dello stesso da parte di una persona responsabile della loro sicurezza.

- Le parti accessibili possono surriscaldarsi durante l'uso. Tenere i bambini a distanza.
- Una spina con tutti i poli deve essere incorporata nel cablaggio fisso secondo le norme di cablaggio.
- Se il cavo di alimentazione è danneggiato, deve essere sostituito dal produttore, dal centro di assistenza o dal personale qualificato per evitare rischi.
- Non usare detersivi eccessivamente abrasivi o raschietti metallici appuntiti per pulire il vetro della porta del forno in quanto possono graffiare la superficie e frantumare lo stesso.
- Non usare pulitori a vapore.
- Questi dispositivi sono destinati a funzionare con un timer esterno o un sistema di controllo remoto separato.

CONSIGLI DI SICUREZZA

- Non usare il forno a piedi nudi. Non toccare il forno con mani o piedi bagnati o umidi.
- Per il forno: non aprire la porta del forno spesso durante la cottura.
- L'elettrodomestico deve essere installato e messo in funzione da un tecnico autorizzato. **Il produttore non è responsabile per danni che possono derivare da un posizionamento e da un'installazione errati da parte di personale non autorizzato.**
- Non lasciare alcun oggetto sulla porta o sul cassetto del forno aperti: si può creare uno squilibrio nell'elettrodomestico o rompere la porta.
- Alcune parti dell'elettrodomestico possono restare calde a lungo: attendere che si raffreddino prima di toccare i punti esposti direttamente al calore.
- Se non si usa l'elettrodomestico per un lungo periodo, scollegarlo dalla presa.

MONTAGGIO DEL FORNO ALL'INTERNO DELLA CUCINA

Inserire il forno nell'apposito spazio all'interno della cucina; può essere inserito sotto un piano di lavoro o in un mobile verticale. Fissarlo in posizione avvitando le viti nei due fori di fissaggio nel telaio. Per individuare i fori di fissaggio, aprire la porta del forno e guardare all'interno. Per consentire un'adeguata ventilazione, rispettare le misure e le distanze durante il fissaggio.

IMPORTANTE

Per il corretto funzionamento del forno, il vano nella cucina deve essere adeguato. I pannelli dell'unità cucina vicini al forno devono essere in materiale resistente al calore. Assicurarsi che le colle delle unità in legno siano resistenti a temperature di almeno 120 °C. La plastica e la colla che non resistono a tali temperature si scioglieranno e deformeranno l'unità. Una volta che il forno è stato installato al suo interno, isolare completamente le parti elettriche. –questo è un requisito di sicurezza legale. Fissare saldamente in posizione tutte le protezioni che sono impossibili da rimuovere senza appositi strumenti. Rimuovere la parte posteriore del mobile per assicurare la circolazione di un'adeguata corrente di aria intorno al forno. Il piano cottura deve avere uno spazio posteriore di almeno 45 mm.

DICHIARAZIONE DI CONFORMITÀ

Una volta rimosso il forno dalla sua confezione, assicurarsi che non sia danneggiato in nessun punto. In caso di dubbi, non utilizzarlo ma contattare una persona professionalmente qualificata. Tenere i materiali di imballaggio come buste di plastica, polistirolo o chiodi fuori dalla portata dei bambini.



MODO D'USO

- Se non è necessario impostare la durata di cottura, quando si ruota in senso antiorario la manopola del timer su "Stay on", il timer non torna a "0" automaticamente e il forno resta acceso.
- Se non è necessario impostare la durata di cottura, ruotare in senso orario il timer per impostarlo sul tempo necessario. Quando viene raggiunto il tempo di cottura impostato, il timer torna a "0" automaticamente con il suono di "Ding, Ding, Ding" e il forno si spegne.
- Impostare le funzioni ruotando la manopola delle funzioni verso il livello desiderato.
- Impostare la temperatura ruotando la manopola della temperatura. Il forno inizia automaticamente la cottura dopo l'impostazione della funzione, del tempo e della temperatura.
- Se il forno non è in uso, impostare sempre tutte le manopole su "0"

DESCRIZIONE DEL PRODOTTO

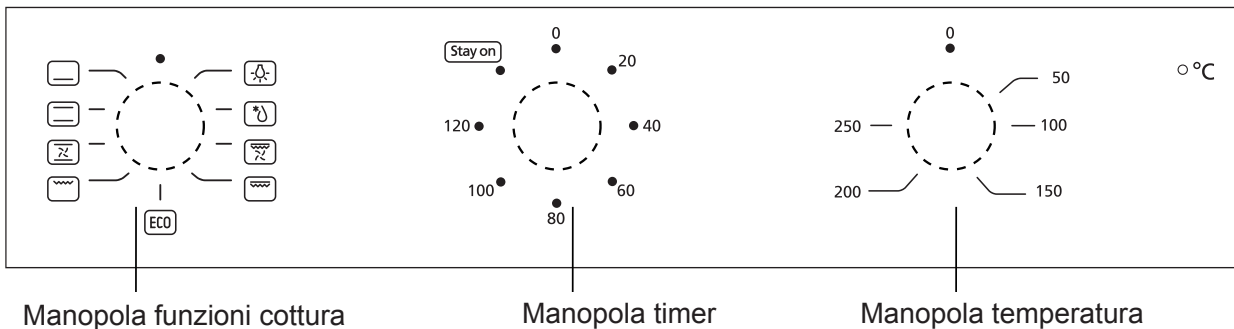

Simbolo	Descrizione della funzione
	Lampadina forno : per accendere la luce nel forno senza attivare una funzione di cottura.
	Scongelamento: la circolazione dell'aria a temperatura ambiente consente uno scongelamento del cibo più rapido (senza usare altre fonti di calore). È un modo delicato ma rapido per accelerare il tempo di scongelamento di piatti già pronti, prodotti ripieni di crema, ecc.
	Cottura Statica Inferiore: Il calore viene irradiato dal fondo del forno. Usare questa opzione per rosolare la base del cibo. Questa funzione è adatta per ricette a cottura lenta o per riscaldare le pietanze.
	Cottura Tradizionale: gli elementi riscaldanti della parte superiore e inferiore riscaldano uniformemente il cibo esposto. La cottura in forno e l'arrosto sono possibili solo a un livello singolo.
	Tradizionale + Ventola: l'elemento riscaldante superiore e quello inferiore funzionano insieme alla ventola. L'elettrodomestico cuoce uniformemente e rapidamente in ogni punto.
	Grill Per grigliare piccole quantità di cibo e per dorarne la superficie. Posizionare gli alimenti nella parte centrale sotto l'elemento riscaldante della griglia.
	Doppio grill: la parte interna dell'elemento riscaldante e quella esterna nella parte superiore del forno funzionano insieme. Adatto per di grandi quantità di cibo.
	Doppio grill con ventola: la parte interna dell'elemento riscaldante e quella esterna nella parte superiore del forno funzionano con la ventola. Adatto per la cottura di grandi quantità di cibo e di grandi dimensioni.
	E' indicata per le cotture delicate a basso consumo di energia.

La luce all'interno della cavità del forno è accesa in tutte le funzioni tranne nella funzione eco dove risulterà spenta.

ACCESSORI

Griglia: per griglia, piatti, tortiere con elementi da arrostiti o grigliare.

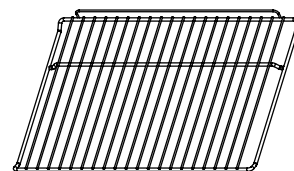

Leccarda: per la cottura di grandi quantità di cibo come torte umide, pasticcini, cibo congelato, ecc. o per raccogliere grasso/fuoriuscite e succhi della carne.

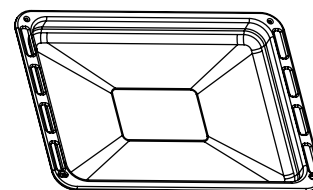

AVVISO POSIZIONAMENTO RIPIANO:

Per garantire un funzionamento sicuro dei ripiani del forno, è fondamentale posizionarli correttamente tra le guide laterali. Usare i ripiani e le teglie solo tra il primo e il quinto livello.

I ripiani devono essere usati nella giusta direzione per garantire che durante l'attenta rimozione degli stessi o della teglia gli alimenti caldi non scivolino via.

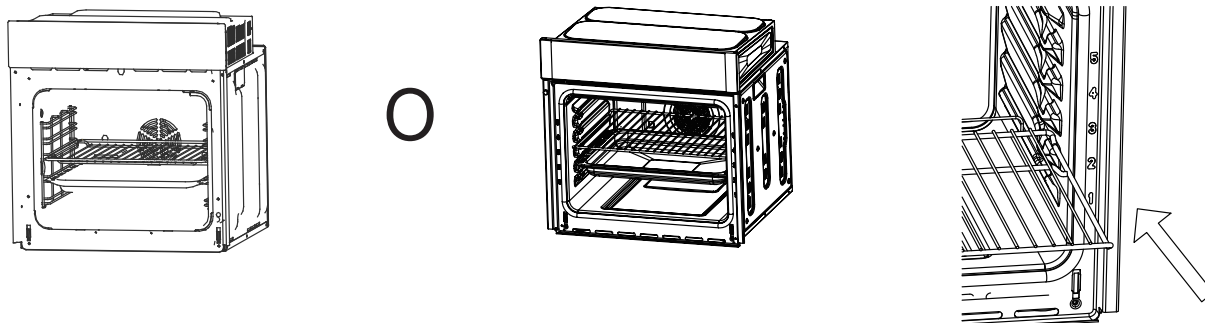

SOSTITUZIONE LAMPADINA

Per la sostituzione della lampadina procedere come segue:

- 1> Scollegare l'alimentazione dalla presa di alimentazione o spegnere l'interruttore della presa di alimentazione dell'unità.
- 2> Svitare il coperchio della lampadina di vetro ruotandolo in senso antiorario (notare che può essere rigido) e sostituire la lampadina con una nuova dello stesso tipo.
- 3> Avvitare nuovamente il coperchio della lampadina di vetro.

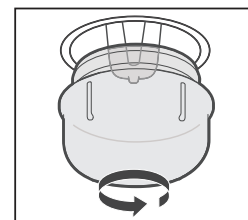

NOTA: usare solo lampadine alogene 25-40W/220V-240V, T300°C.

FISSARE IL FORNO AL MOBILE

1. Inserire il forno nel vano del mobile.
2. Aprire la porta del forno.
3. Fissare il forno al mobile della cucina con due distanziatori "A" adatti per i fori nel telaio del forno e per le due viti "B".

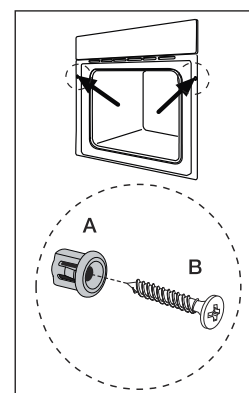

APERTURE PER VENTILAZIONE

Una volta terminata la cottura o durante lo stato pausa o in attesa, se la temperatura al centro del forno supera i 75 gradi, la ventola di raffreddamento continuerà a funzionare per 15 minuti; se invece è inferiore a 75 gradi, si fermerà prima.

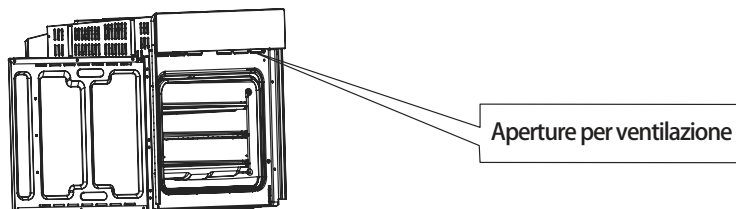

COLLEGAMENTO DEL FORNO

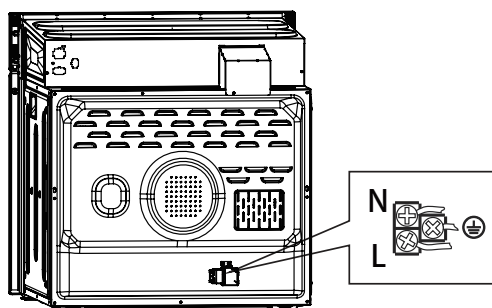

INSTALLAZIONE

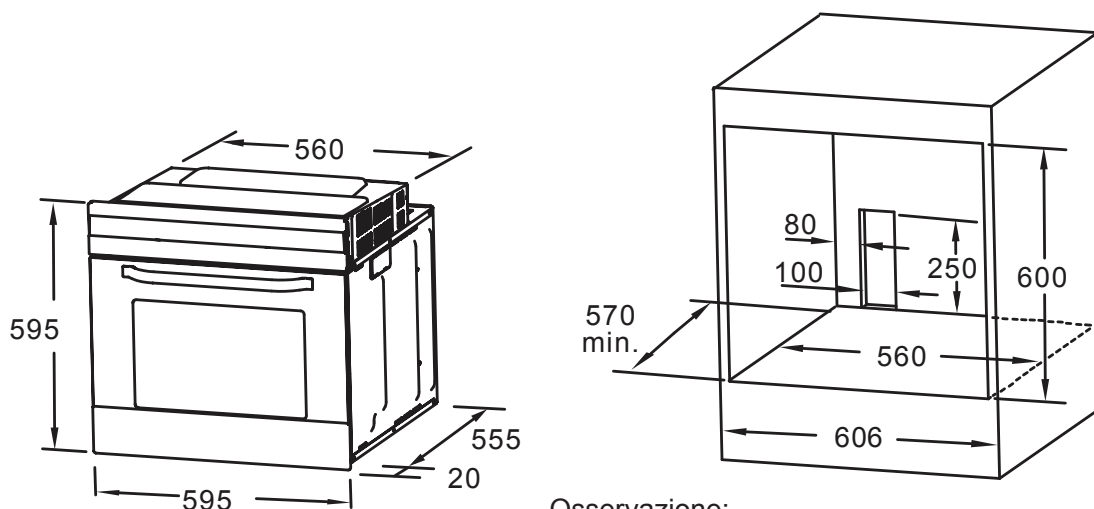

Osservazione:

1. Solo le deviazioni positive sono ammissibili per tutte le dimensioni.
2. Il mobile non comprende l'interruttore o la presa.

NOTA: il numero di accessori in dotazione dipende dall'elettrodomestico acquistato.

RIMOZIONE DELLA PORTA DAL FORNO (OPZIONALE)

Le porte rimovibili consentono il pieno accesso all'interno del forno per una manutenzione più facile e veloce.

1. Per rimuovere la porta, aprirla completamente. Quindi tirare indietro la chiusura sulla cerniera della porta. (Figura 1)



Figura 1

2. Chiudere la porta a circa 15°. Sollevarla ed estrarla lentamente dal forno. (Figura 2)

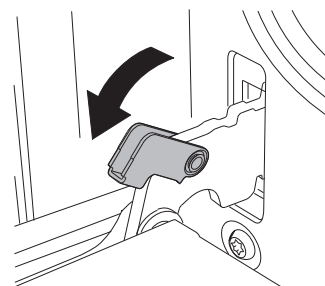

Figura 2

3. Posizionare la porta di piatto con il coperchio superiore della porta verso sé, mettere le mani sul vetro e spingerlo verso il forno. (Figura 3)

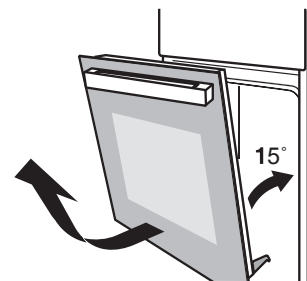

Figura 3

4. Separare il vetro con cura sollevandolo di circa 25°. (Figura 4)



Figura 4

5. Spingere il vetro nella posizione indicata dalla freccia nella Figura 5. Estrarre delicatamente il vetro dalla cavità.

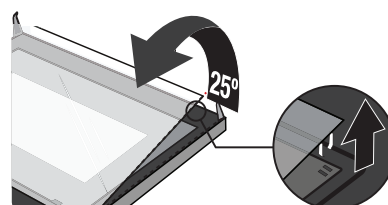

Figura 5

6. Dopo aver estratto il vetro interno, rimuovere il vetro centrale come mostrato nella Figura 6.

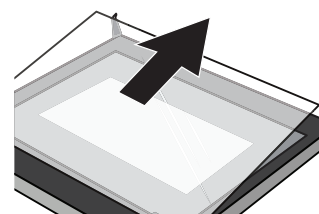

Figura 6

7. Completata la pulizia, invertire la procedura precedente per rimettere la porta nella sua posizione originale.

Cotture suggerite per la modalità ECO

Pietanza	Temperatura (°C)	Livello	Tempo (minuti)	Preriscaldamento
Gratinato di Patate e Formaggio	180	1	90-100	No
Cheesecake	160	1	100-150	No
Polpettone	190	1	110-130	No

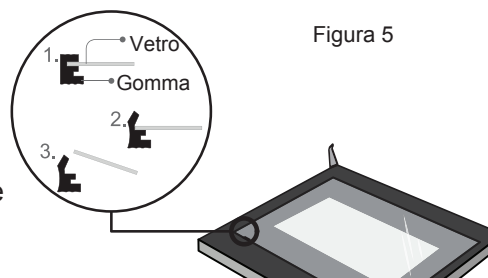
PULIZIA E MANUTENZIONE

Per motivi estetici e di affidabilità, mantenere l'unità pulita. Il design moderno dell'unità richiede una manutenzione minima. Le parti dell'unità che vengono a contatto con gli alimenti devono essere pulite regolarmente.

- Prima di qualsiasi manutenzione e pulizia, scollegare l'alimentazione.
- Impostare i comandi su OFF.
- Attendere finché l'unità non è più calda; una pulizia con l'unità leggermente calda è più facile.
- Pulire la superficie dell'unità con un panno umido, una spazzola morbida o una spugna sottile e quindi asciugare. Nel caso di sporco ostinato, usare acqua calda con un detersivo non abrasivo.
- Per la pulizia del vetro della porta del forno non usare detersivi abrasivi o raschietti metallici appuntiti perché potrebbero graffiare la superficie o danneggiare il vetro.

Non lasciare mai sostanze acide (succo di limone, aceto) sulle parti in acciaio inossidabile.

Non usare un dispositivo ad alta pressione per pulire l'unità. Le teglie possono essere lavate con un detersivo delicato.

Questo dispositivo è contrassegnato in conformità alla direttiva europea 2012/19/EU sui rifiuti di apparecchiature elettriche ed elettroniche (RAEE).

Assicurandosi che questo prodotto sia smaltito correttamente, si contribuirà a prevenire potenziali conseguenze negative per l'ambiente e la salute umana, che potrebbero altrimenti essere causate da una gestione inadeguata dei rifiuti di questo prodotto. Il simbolo sul prodotto indica che questo prodotto non può essere trattato come rifiuto domestico. Invece deve essere consegnato all'apposito punto di raccolta per il riciclaggio di apparecchiature elettriche ed elettroniche.

Lo smaltimento deve essere effettuato in conformità con le normative ambientali locali per lo smaltimento dei rifiuti. Per informazioni più dettagliate su trattamento, recupero e riciclaggio di questo prodotto, contattare l'ufficio comunale locale, il servizio di smaltimento rifiuti domestici o il negozio in cui è stato acquistato il prodotto.



Master Kitchen
Midea Italia srl
Made in P.R.C.



Master Kitchen

Built in Oven Prime Series - User Manual



Before operation of your built in oven, please read carefully this manual, which contains information about correct usage and maintenance of the product, in order to preserve its design and function performance.

Introduction

Thank you for purchasing a Master Kitchen oven.

Please read carefully these instructions before operation of your appliance, in order to use it properly and prevent potential hazards.

Please keep safely this instruction manual for future references.

In case of any doubts about the content of this instruction manual, please contact our customer support center.

The manufacturer can not be deemed responsible for any damages or injuries related to the improper installation or usage of the product.

The manufacturer reserves its right to modify the products, if needed to assure the best performance to customer, without affecting the main operations and security features of the products.

Models



MKO 82/12-M BK
EAN code 6944271650271



MKO 82/12 MS XS
EAN code 6944271646939



MKO 802/12-PR MS BK
EAN code 6944271646847



MKO 802/12-PR MS XS
EAN code 6944271646830



MKO 902-PR M XS
EAN code 6944271646861



MKO 902-PR M BK
EAN code 6944271646915



MKO 902-PR M WH
EAN code 6944271646977



MKO 906-PR M XS
EAN code 6944271646878



MKO 1006-PR M P XS
EAN code 6944271646885

CONTENTS

5	SECURITY INFORMATION
5	General Information
5	Warnings
6	Damages
8	INSTALLATION AND GENERAL DIMENSIONS
10	COOKING FUNCTIONS
13	FIRST USE
14	GETTING TO KNOW YOUR OVEN
14	Control panel for mechanical models
17	Control panel for Easy Control models
20	Cooling fan (for all models)
21	Accessories
22	Removal of wire frames (if available)
23	Removal of oven door
24	Removal and cleaning of internal glasses from oven door
26	Lamp replacement
27	Power cable replacement
28	GENERAL ENERGY SAVING INDICATIONS
28	ENVIRONMENT
29	HEALTH
29	CLEANING AND MAINTENANCE OF YOUR APPLIANCE
32	TROUBLESHOOTING
33	CUSTOMER CARE
33	Maintenance sheet
34	GENERAL STATEMENTS
36	FOOD QUALITY GRADE: COMPLIANT TO EN 60350-1
36	OTHER TYPICAL RECIPES
37	OTHER TYPICAL RECIPES
37	COOKING IN GREEN MODE
37	ENERGY SAVING: COMPLIANT TO EN 60350-1
38	DATA SHEET (EU 65/2014 & EU 66/2014)

SECURITY INFORMATION

GENERAL INFORMATION

This equipment is only intended for household use and can not be used outdoor. For security purposes, it shall be used only in built-under installations. Do NOT USE this equipment in unstable places, such as boats or caravans.

After unpacking the appliance, check it for damages and do not connect to power supply if it is damaged. Only qualified personnel can connect the appliance to power supply without a plug. Any damages due to improper connection are not covered by warranty. This oven must be operated only for normal household cooking and is not intended for professional use. Any other use is not allowed. Do not leave the appliance unattended during operation.

This appliance can be used by children less than 8 years old and by people with physical, sensorial or mental impairing, or by persons with poor experience and knowledge about the product, provided that they are properly attended or trained about the proper use of the equipment and the involved risks.

Children shall not play with or around this equipment. Children can not take care of cleaning and general maintenance of the product, unless they are older than 8 and are constantly supervised during operations.

Keep children away from packaging materials.

Keep children and pets away from the equipment during operation or cooling, as they can be burnt by accessible components.

WARNINGS

Electric Shock Hazard!

1. Improper servicing could be dangerous. Only experienced technical personnel can take care of servicing and replacing damaged power cables. If the equipment is damaged, please disconnect it from power supply or activate the circuit breaker switch. Contact customer support.
2. If the cable touches hot oven components, it can melt. Prevent cable from touching hot appliance components.
3. Do not use spray or vapour cleaners, as they can cause electric shocks.
4. If the equipment is damaged, it can cause electric shocks. Do not power on damaged equipments. If the equipment is damaged, please disconnect it from power supply or activate the circuit breaker switch. Please contact the customer support.

Hazard of burns!

1. During operation the equipment is hot. Do not touch internal surfaces, accessories and heating elements of the equipment.
2. Keep children away from the equipment during operation and while it is cooling after use.

3. Baking pans and other accessories become hot during use. Wear protection gloves to remove accessories and baking pans from oven.
4. Alcohol vapours may cause fire in the hot cooking chamber. Never cook foods if their preparation requires big quantity of alcoholic liquid.
5. Pay attention when you open the oven door, as it may leak invisible hot vapours. Keep a certain distance from oven when it is opened.

Hazard of injuries!

1. Scratched glass of the oven door may cause damage. Don not use abrasive cleaners or scrapers on the glass.
2. Hinges of the oven door may move during opening and closing, so you might get trapped in them. Keep your hands away from hinges.

Fire hazard!

1. Flammable objects inside the oven can cause fires. Do not keep flammable objects inside the oven. Do not open the oven door when there is smoke inside. Turn off the equipment and disconnect it from power supply or activate the circuit breaker switch.
2. When the oven door is opened, air might flow inside. Baking paper may touch heating elements and cause fires. Do not place baking paper directly on oven accessories during pre-heating. Keep baking paper fixed by a plate or baking pan. Use baking paper to cover only the needed surface. Baking paper shall not stick out of the pans.

Magnetic hazard!

The control panel and its elements contain permanent magnets. They can affect other electronic devices, such as pacemaker or mini-insulin pumps. Keep at least 10 cm away from the control panel, if you wear electronic devices.

DAMAGES

Attention!

This equipment can be easily damaged!

- **To avoid coating damage:**

1. Do not place heat-resistant pots or other objects directly on the lower surface of the equipment during cooking process (it is allowed only in case of defrosting).
2. Do not place aluminum foils directly on the lower surface of the equipment.
3. Do not place water directly inside the hot equipment.
4. Do not keep wet dishes and food inside the equipment after cooking completion.
5. Pay attention when inserting or removing accessories.

Coating discoloration does not affect the performance of equipment. This is not a problem according to applicable laws

- **Aluminum foils:** aluminum foils inside the oven shall not touch the internal glass of oven door. This could cause a permanent discoloration of glasses.
- **Aluminum foils:** aluminum foils inside the oven shall not touch the internal glass of oven door. This could cause a permanent discoloration of glasses.
- **Silicon pans:** Do not use silicon pans, mats, lids or other accessories containing silicon, if they are not approved for oven cooking. This could damage the oven sensor (if available).

- **Moisture inside the oven:** after a long time, the presence of moisture inside the oven could cause corrosion. Let the equipment dry after usage.
- **Cooling with oven door opened:** after high temperature operations, let the oven cool down with closed door. Do not force anything against the oven door, as even the presence of the smallest gap could damage the upper part of the oven (control panel).
- **Fruit juices:** when cooking juicy fruit pies, do not fill too much the baking pan. Any leakage of fruit juices could cause stains that can not be removed. If available, you can use a deeper baking pan.
- **Dirty sealings:** if the sealing between equipment and oven door is too dirty, the latter could not close properly during operation, damaging the oven front (control panel). So, it is recommended to clean regularly the sealing.
- **Do not use oven door as seat or desktop:** do not seat on the opened oven door. Do not place or hang anything on it. Do not place pans or other accessories on the oven door.
- **Food leftovers:** food or fat leftovers inside the oven cavity might cause fires, so regular cleaning of oven is recommended after each cooking.
- **Oven handling during installation:** do not grasp or lift the equipment by the handle of the oven door. This handle is not designed to bear the equipment weight, so it could be broken.
- **Using the residual heat** when the oven is powered off to keep food warm, can cause high moisture inside the cavity. This can cause condensation and corrosion, damaging your high quality equipment and your whole kitchen. Avoid condensation by opening the oven door or using the “Defrost” mode.

INSTALLATION AND GENERAL DIMENSIONS

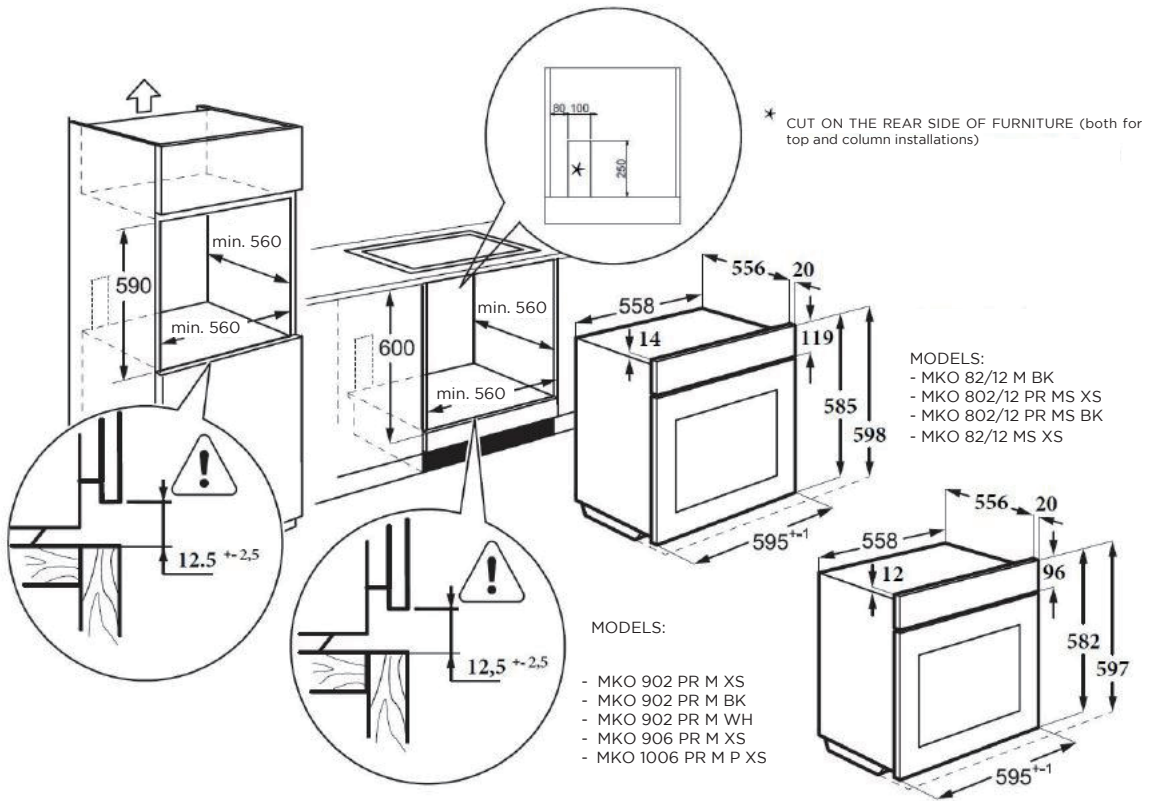

To grant the secure operation of this appliance, please check that its installation is compliant to the instructions. Any damages due to improper installation are not covered by the warranty.

During installation, wear protective gloves to prevent cutting your hands due to sharp edges.

WARNING, the oven shall not be installed behind a decorative panel to prevent equipment overheating.

Do not install and operate the equipment if it is damaged.

Before powering on the equipment, please remove from it all packaging materials and any protective adhesive film.

Sizes stated in the above picture are expressed in mm.

FEATURES OF INSTALLATION FURNITURE: The components of built-under furniture (plastic or veneered wood materials) must use heat-resistant glue materials (at least 100°C). Using unsuitable materials and glues may cause damages and deformation.

Mounting furniture must allow the proper laying of electric cables and be robust enough to bear the equipment weight.

The oven must be safely mounted in the dedicated slot, and can be fitted inside a column or under the top of modular furniture, allowing the needed ventilation.

Assembly instruction:

- 1) Place the equipment in its slot
- 2) Open the oven door
- 3) Fix oven to furniture, inserting the included spacers (A) and screws (B) in the corresponding holes on the oven sides.
- 4) Hide screws with the dedicated covers

ATTENTION: screws (B) fixing the oven to furniture must be placed properly, without tightening them too much to prevent damages to spacers (A).

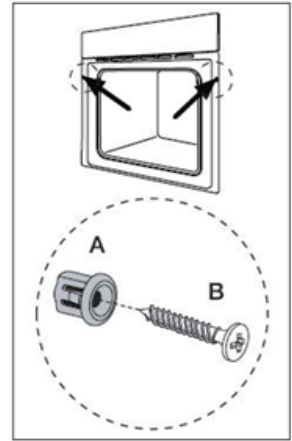

Connection to mains power:

- The oven is provided with a three-wired power cable and free terminals.
- If the oven is permanently connected to power supply, provide it with a disconnection switch and a suitable opening contact distance (at least 3 mm) to allow full disconnection of the equipment under the conditions listed in Overvoltage Category III.

Verify:

1. Use plug and outlet rated for 16 Ampere currents
2. Plug and outlet must be easily accessible and placed in such a way that no live parts may be reached while inserting or removing the plug.
3. The plug must be easily inserted.
4. The oven shall not touch the inserted plug, when it is installed in furniture.
5. Do not connect the terminals of two different equipments to the same plug.
6. If needed, the power cable shall be replaced with one of 3 x 1,5 mm² (H05VV-F or H05RR-F type)
7. When plugging the equipment, check the correct polarity of free terminals (Brown = Phase; Blue = Neutral; Yellow-green = Ground)

N.B. Make sure that the household electric line (voltage, maximum power and current) matches the values specified for your oven.

GROUNDING

- The installation must be provided with a grounding wire, usually marked by a protective sleeve of yellow-green color.
- All household appliances must be grounded.
- This wire must be connected to a remote earth system (usually deeply buried rods), which allows to discharge the current possibly accumulated on the surface of the involved equipments.

PHASE

NEUTRAL

GROUND









TERRA

COOKING FUNCTIONS

Your appliance has several operation mode which allows a simple use. The following table contains the explanation of different cooking functions available in the oven you purchased. The related symbols will allow you to easily identify the cooking functions more suitable to your foods.











Cooking modes for 8-function Ovens + ECO

**MKO 82/12-M BK; MKO 82/12 MS XS; MKO 802/12-PR MS BK;
MKO 802/12-PR MS XS**

Function type	Temperature	Used for
 Light	/	Used to light up the oven cavity without turning on any heating element.
 Defrosting	/	Used for gently defrosting of frozen foods (this function does not use heating elements).
 Double grill with ventilation	50°C-250°C	This cooking function combines the use of grill, upper resistance and fan. It's the ideal choice for cooking thick meat, such as shin of pork and turkey, as it makes these foods crunchy outside and soft and juicy inside.
 Double grill	50°C-250°C	This function uses the heat generated by upper resistance and grill. The combined action of convection and irradiation allows to grill great quantity of small pieces of meat, such as sausages, steaks and pork-chops, or to toast bread and finely cook many foods.
 Green	50°C-250°C	This function is used for gentle cooking while saving power.
 Grill	50°C-250°C	This function activates the upper heating element for optimal cooking (gratin) through irradiation of small quantity of meat, such as sausages and steaks.
 Static cooking with ventilation	50°C-250°C	The upper and lower resistances are used together with the rear fan to obtain an uniform heat distribution, granting a quicker and homogeneous cooking of foods. This functions allows the multilevel cooking of more foods without mixing flavors and odors.
 Traditional cooking	50°C-250°C	Traditional cooking uses the combined action of both upper and lower resistance. Heat is distributed inside the oven cavity by natural convection. This is the ideal choice to cook dishes and foods of small or medium thickness using only one shelf.
 Lower Static cooking	50°C-250°C	This function uses only the lower resistance, focusing the heat on the lower surface of the oven cavity. It's the ideal choice to complete cooking and prepare crisp pizzas, pies and tarts.











Cooking modes for 9-function Ovens + ECO

MKO 902-PR M XS; MKO 902-PR M BK; MKO 902-PR M WH; MKO 906-PR M XS

Function type	Temperature	Used for
 Light	/	Used to light up the oven cavity without turning on any heating element.
 Defrosting	/	Used for gently defrosting of frozen foods (this function does not use heating elements).
 Green	50°C-250°C	This function is used for gentle cooking while saving power.
 Lower Static cooking	50°C-250°C <small>for mechanical models</small> 60°C-120°C for Easy Ctr and Touch Ctr	This function uses only the lower resistance, focusing the heat on the lower surface of the oven cavity. It's the ideal choice to complete cooking and prepare crisp pizzas, pies and tarts.
 Traditional cooking	50°C-250°C	Traditional cooking uses the combined action of both upper and lower resistance. Heat is distributed inside the oven cavity by natural convection. This is the ideal choice to cook dishes and foods of small or medium thickness using only one shelf.
 Static cooking with ventilation	50°C-250°C	The upper and lower resistances are used together with the rear fan to obtain an uniform heat distribution, granting a quicker and homogeneous cooking of foods. This functions allows the multilevel cooking of more foods without mixing flavors and odors.
 Grill	50°C-250°C <small>for mechanical models</small> 180°C-240°C for Easy Ctr and Touch Ctr	This function activates the upper heating element for optimal cooking (gratin) through irradiation of small quantity of meat, such as sausages and steaks.
 Double grill	50°C-250°C <small>for mechanical models</small> 180°C-240°C for Easy Ctr and Touch Ctr	This function uses the heat generated by upper resistance and grill. The combined action of convection and irradiation allows to grill great quantity of small pieces of meat, such as sausages, steaks and pork-chops, or to toast bread and finely cook many foods.
 Double grill with ventilation	50°C-250°C <small>for mechanical models</small> 180°C-240°C for Easy Ctr and Touch Ctr	This cooking function combines the use of grill, upper resistance and fan. It's the ideal choice for cooking thick meat, such as shin of pork and turkey, as it makes these foods crunchy outside and soft and juicy inside.
 Convention cooking	50°C-250°C <small>for mechanical models</small> 50°C-240°C for Easy Ctr and Touch Ctr	This function activates the circular resistance and the fan, allowing a more uniform and quicker cooking of foods. This function also allows multilevel cooking of more foods at the same time, without mixing flavors and odors.

Cooking modes for 9-function Ovens + ECO + PYRO

MKO 1006-PR M P XS

Function type		Temperature	Used for
	Light	/	Used to light up the oven cavity without turning on any heating element.
	Defrosting	/	Used for gently defrosting of frozen foods (this function does not use heating elements).
	Green	50°C-250°C	This function is used for gentle cooking while saving power.
	Lower Static cooking	60°C-120°C	This function uses only the lower resistance, focusing the heat on the lower surface of the oven cavity. It's the ideal choice to complete cooking and prepare crisp pizzas, pies and tarts.
	Traditional cooking	50°C-250°C	Traditional cooking uses the combined action of both upper and lower resistance. Heat is distributed inside the oven cavity by natural convection. This is the ideal choice to cook dishes and foods of small or medium thickness using only one shelf.
	Double grill with ventilation	50°C-250°C	The upper and lower resistances are used together with the rear fan to obtain an uniform heat distribution, granting a quicker and homogeneous cooking of foods. This functions allows the multilevel cooking of more foods without mixing flavors and odors.
	Grill	180°C-240°C	This function activates the upper heating element for optimal cooking (gratin) through irradiation of small quantity of meat, such as sausages and steaks.
	Double grill	180°C-240°C	This function uses the heat generated by upper resistance and grill. The combined action of convection and irradiation allows to grill great quantity of small pieces of meat, such as sausages, steaks and pork-chops, or to toast bread and finely cook many foods.
	Double grill with ventilation	180°C-240°C	This cooking function combines the use of grill, upper resistance and fan. It's the ideal choice for cooking thick meat, such as shin of pork and turkey, as it makes these foods crunchy outside and soft and juicy inside.
	Convention cooking	50°C-240°C	This function activates the circular resistance and the fan, allowing a more uniform and quicker cooking of foods. This function also allows multilevel cooking of more foods at the same time, without mixing flavors and odors.
Pyrolytic mode	Pyrolysis	about 450°C	Used for easy cleaning of the cooking cavity

Light for all models

When you power on the appliance in any mode, the lamp inside the cooking cavity is always turned on until the end of operations (except for the ECO function). The mode "Light" can be used for several activities, such as cleaning or cooking preparation (in this function no heating elements are on).

FIRST USE

Before using the appliance for cooking foods **the first time**, it is needed to carefully clean the oven cavity and related accessories.

1. Remove any adhesive, protective films and all packaging materials.
2. Remove all accessories and side wire frames inside the oven (see the relevant chapter for removal of side frames).
3. Clean carefully accessories and side grills with soap and water, using a soft sponge or a soft brush.
4. Verify that inside the oven there are no residual packaging materials, such as polystyrene and wood leftovers, which could cause fires.
5. Clean flat surfaces of the oven door and cavity with a soft damp cloth.
6. To remove the smell when the appliance is new, heat the empty equipment with the oven door closed.
7. Allow a suitable ventilation in the kitchen when the equipment is heated for the first time. Keep children and pets away from kitchen during this operation. Close doors of adjacent rooms.
8. When the oven is powered on for the first time, setup the equipment as in the following:

Settings	
Heating mode	
Temperature	250°C
Time	1h

Once the equipment is cooled down:

1. Clean flat surfaces of the oven door and cavity with soap and water, using a soft sponge or a soft brush.
2. Dry all surfaces.
3. Install the side wire frames and plug in accessories.

GETTING TO KNOW YOUR OVEN

EQUIPMENT IDENTIFICATION

This chapter describes the control panel and accessories. It also includes information about several functions of your appliance.

Note: Details and colors of the product may change according to the actual model.

CONTROL PANEL FOR MECHANICAL MODELS

Models: MKO 82/12 M BK; MKO 82/12 MS XS; MKO 802/12-PR MS BK; MKO 802/12-PR MS XS;

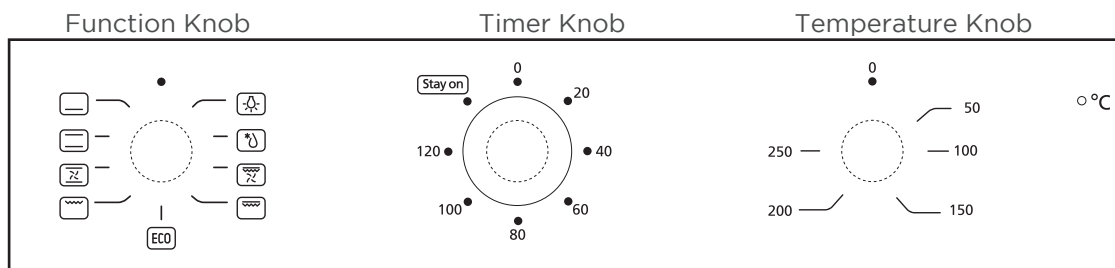

Models: MKO 902-PR M XS; MKO 902-PR M BK; MKO 902-PR M WH

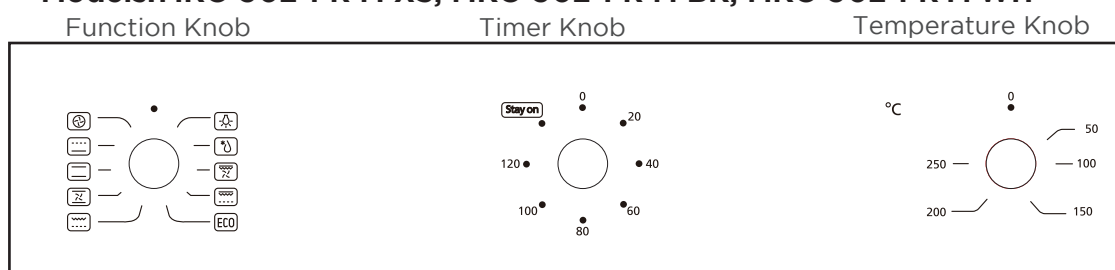

Warning: the picture is only for reference and could not match exactly the model you purchased.

Knobs

Turning the knobs, you can set up the oven operation modes. Each knob is located exactly in the middle of the icons printed on the control panel glass, so that you can easily configure your appliance (simply and directly). The operation modes do not have limitations, so that you can get the most from your appliance.

Light indicator

This indicator is a kind of light showing if the appliance resistances are being used or not. When the appliance is powered on, the light indicator will turn on and off: it will be on when at least one of the heating elements is in use, while it will be off when no heating element is used.

Cooking functions selection

When the knob is set to "o", the cooking function is not defined. To select one cooking function, you can turn the knob located on the left side of the control panel. To select the preferred cooking function, you need to turn the knob so that the pointer on it indicates the requested function.

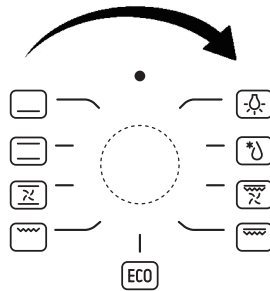

Temperature setting

The selection of the cooking temperature can be done in a similar way as the selection of the cooking function. You can use the temperature knob located on the right side of the control panel. To select the preferred cooking temperature, you need to turn the knob so that the pointer on it indicates the requested temperature.

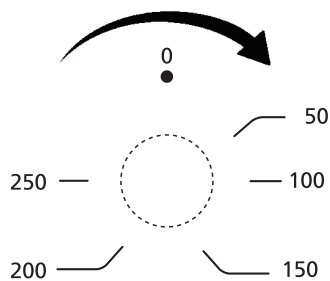

Powering on

Once you have setup cooking function and temperature, you can power on the appliance by turning the time knob in the middle of the control panel. To select the preferred cooking time, you need to turn the knob so that the pointer on it indicates the requested time. Now the oven is powered on (you can set a maximum cooking time of 2 hours).

Note

The knob for TIMER configuration turns on the oven. Once you move the knob from its original position, the oven is working. Once the oven heating has started, the knob will slowly turn anticlockwise, until the knob pointer reaches its original position "o". Then, the oven will sound a warning beep and will turn off (once the oven is turned off, its cavity maintains for a long time the set cooking temperature, so in order to prevent overcooking or burnings, remove the food from oven).

Turning anticlockwise the knob for TIMER control from starting position "0", it will stop on the STAY ON position. This means that the oven will be continuously working without timer control and will not automatically turn off. To use this mode, leave the equipment attended by an expert person, who knows how to use the oven safely and the related risks.

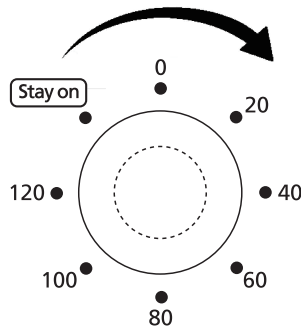

Indicator

When the oven is in operation, the indicator on the right side of the control panel lights on, and during the cooking time it turns on and off according to the activation of heating elements.

Setting changes

When the oven is in operation, you can turn the knobs on the control panel to change the cooking settings (function, temperature and time).

Changing function when the oven is in use, changes the cooking mode (if the knob is turned to LIGHT and DEFROST positions, the heating elements will be turned off, while if the knob is moved back to position "0", the equipment will be powered off, even if the timer is still running).

Turning the temperature knob when the oven is running changes the cooking temperature of food. If during the cooking time the knob is turned to "0" position, the heating elements will be turned off, while the light and timer are still turned on, and the cooling fan is running according to the oven temperature.

Turning the knob for timer control when the oven is working, changes the remaining cooking time while the food is cooking. Turning the knob to "0" position during the cooking process, the equipment will be powered off.

When the oven is turned off, the light indicator will be off too.

Attention!

After usage, the oven is very hot inside, even when powered off. Never touch internal surfaces or elements of the oven. Wear protective gloves to remove accessories and pans from the oven, and let the equipment cool down. To prevent burnings or injuries, keep children away from the oven.

Note

Changing cooking function/temperature/time while the oven is running can have negative effects on the cooking process. So it is recommended to make any changes only if you are very expert.

Attention!

Opening the oven door when it is working does not stop oven operation. Please pay particular attention to prevent burnings.

CONTROL PANEL FOR EASY CONTROL MODELS

Models: MKO 906-PR M XS; MKO 1006-PR M P XS

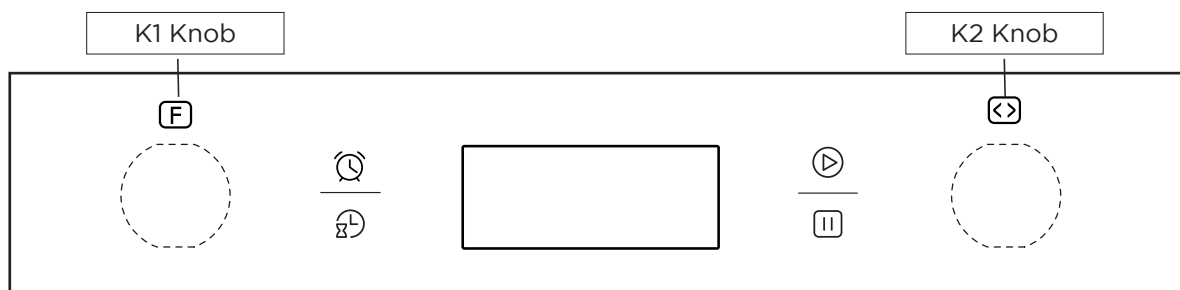



Warning: the picture is only for reference and could not match exactly the model you purchased.

To turn the Push Pull knobs, press and pull them on, then do not close them again while the oven is running.

Clock Settings

After connecting the oven to mains power, the Display will show "0:00" with steady light. Then, apply the following steps to setup the clock:



- 1 - Pressing  key, the hour digits will start blinking.
- 2 - Turn the right knob "K2" to setup hours (value between 0 and 23).
- 3 - Press  key to confirm selection. Then, the minute digits will start blinking.
- 4 - Turn the right knob "K2" to setup minutes (value between 0 and 59).
- 5 - Press  key to confirm selection and complete settings.

N.B. If the clock is not set, the display will show "0:00".



Setting Cooking Function and Temperature

- 1 - Turning the left "K1" knob selects the desired cooking function.
- 2 - Turning the right "K2" knob selects the desired cooking temperature (*).
- 3 - Press Enter  to confirm oven activation.

You can also turn on the oven soon after selecting the cooking function, by pressing  key. In this case, the oven will set a default cooking temperature according to the selected function.

(*) The Lamp  and Defrost  functions do not allow the setting of cooking temperature, as no heating element is running.

Turning the "K2" knob in the remaining functions will allow changing temperature in 5°C steps. The temperature value will blink, until the center of the oven cavity reaches the set temperature. Once the temperature is reached, the oven will beep briefly and the temperature value will show steady on the display.

When the oven is running, you can pause it by pressing the stop key  . Then, you can resume normal operation according to the functions previously selected, by pressing the start key  . Pressing twice the stop key  will erase the current cooking settings and the oven will enter standby mode.

During normal operation, you can see the current time (if already set) by pressing the  key. After 3 seconds, the display will show again current cooking function, temperature and time.

Setting Cooking Time



You can set the preferred cooking time, so that the oven will automatically power off once this time is elapsed. After setting the preferred function and/or temperature and pressing the power on key  , the display will show 9 hours as default cooking time. This setting can be modified with the following steps:

- 1 - When the oven is running, turn the left "K1" knob to set the cooking time (between 1 minute and 9 hours).
- 2 - Press enter key to confirm  . The oven will start a count down and after its expiration the oven beeps and turn off automatically.

N.B. If, after setting the cooking duration, you don't press the enter key  within 3 seconds, the oven will automatically switch to the previously set cooking duration.



Turn on Oven Light



The light inside the cooking cavity is always turned on for all the cooking and defrosting functions (except the ECO function). You can always turn on the light inside the oven using the related function and use it for example when you are cleaning the appliance.

Turn the left knob "K1", select the function Light  and press the enter key  : the light will turn on inside the oven cavity. To turn off the light and switch to standby mode, press twice the stop key  .

Setting Timer function

The oven Timer function is a common kitchen timer and can be used only when the oven is in standby mode.









- 1 - When the oven is in standby mode, press  key to access the Timer function.
- 2 - Turn the right knob "K2" to setup hours (value between 0 and 9).
- 3 - Press enter key  to confirm.
- 4 - Turn the right knob "K2" to setup minutes (value between 0 and 59).
- 5 - Press start key  to confirm and complete Timer settings. The oven count down will start and after its expiration the oven buzzer will beep 10 times.

During the count down, the Timer can be paused by pressing once the stop key  , while pressing once the start key  resumes again the count down. To clear the Timer function and switch to standby mode, press twice the stop key  .





During the count down, you can see the current time (if already set) by pressing the  key. After 3 seconds, the display will show again the timer count down.

Setting initial time and cooking duration

With this function, you can set the time when the oven turns on automatically and the cooking duration of the food, before the oven turns off automatically (to use this function, you first need to set the clock: see the relevant paragraph).



- 1 - Press key .
- 2 - Turn the right knob "K2" to setup hours (value between 0 and 23)
- 3 - Press key .
- 4 - Turn the right knob "K2" to setup minutes (value between 0 and 59)
- 5 - Then, you DO NOT have to press the key , but you can turn the left knob "K1" to setup the preferred cooking function.
- 6 - Then you can press the enter key  and turn the left knob "K1" and the right knob "K2" to setup the preferred cooking duration and temperature.
- 7 - Press the enter key  to complete settings; the display will show the time and an hourglass icon  always lit on (the display will not show other symbols such as function and temperature...). You can always check the start cooking time by pressing the key : the display will show the initial time for about 3 seconds, then the current time will show again.
- 8 - At the set time, a beep will warn that the cooking is started, while the hourglass symbol  turns off and all the other indicators are shown again (function, temperature and cooking duration).
- 9 - At expiration of the set cooking time, the oven will turn off automatically.



Note

- This setting is not available for the functions Light, Defrost and Meat Probe (if available).
- Once the programming is set, you can always check the defined settings, by pressing once the stop key . The display will show the settings for function, temperature and cooking duration. Press the start key  to go back to previous screen (the display will show hourglass  and time) or press again the stop key  to clear settings of cooking start / stop (the display shows only time).
- Once the programming is set, you can see only the defined cooking start time by pressing the key . After 3 seconds the display will show again current time

Children Lock Function

This function is used to prevent accidental changes to oven settings during the cooking process or in standby mode.

To enter "LOCK" mode, press and hold for 3 seconds the start  and stop  keys at the same time: the system will beep to warn that the function is now enabled.

To "UNLOCK" mode, press and hold again for 3 seconds the start  and stop  keys at the same time: the system will beep to warn that the function is now disabled.

N.B. If the children lock function is enabled during cooking, the oven can be turned off only by first disabling the lock function and then powering off the appliance through the stop key.

Saving Power Function

If there is no operation (turning knobs, pressing keys) for 10 minutes, the oven switches to Saving Power mode and the display turns off (the display no more shows current time). To exit this function you can press any key or turn the knob. The Power Saving function can be enabled manually by pressing for 3 seconds the start key .

Pyrolysis Function (if available)

This function allows an easy and complete cleaning of the oven cavity.

1 - Turn the left knob "K1" and select the Pyrolysis Function (the display will show "PyR").

2 - Press enter key to confirm . The predefined time for this function is 2 hours, but the duration of the cycle can be reduced to 1 hour and 30 minutes by turning the right knob "K1".

Notes:

- a) Before activating the Pyrolysis Function, remove food leftovers and verify that the oven is empty. Remove anything inside the oven (side frames, grills, dripping-pan, pans, backing trays...) as they could be damaged. For removal of the side wire frames, see the relevant chapter.
- b) If the oven door is not closed, the Pyrolysis Function can not be started and the display will show "DOOR".
- c) Once the pyrolysis cycle is ended, the oven switches to cooling mode and the display will show "COOL".

Attention!

During the oven operation, you shall NOT press the push pull knobs, but they shall be kept in external position.

Attention!

After usage, the oven is very hot inside, even when powered off. Never touch internal surfaces or elements of the oven. Wear protective gloves to remove accessories and pans from the oven, and let the equipment cool down. To prevent injuries.

Attention!

Opening the oven door when it is working does not stop oven operation. Please pay particular attention to prevent burnings.

COOLING FAN (for all models)

The cooling fan turns on and off when needed. Hot air can go out through special openings between the oven door and the control panel. To cool down the oven quickly, the cooling fan can continue running for a while and then it turns off automatically.

ATTENTION: do not cover the air vents between the oven door and the control panel as the appliance could overheat.

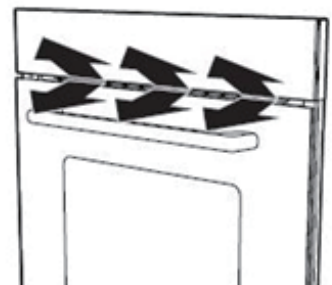

ACCESSORIES

Your appliance is provided with a wide range of accessories. This chapter describes the included accessories and information for their correct usage.

Included accessories

Your appliance includes the following accessories:

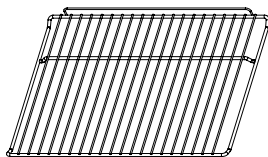

Wire **Grill**

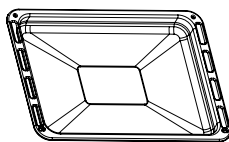

Dripping-pan

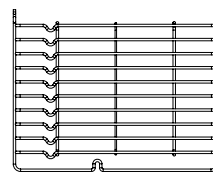

Slider **bracket**

Warning: the picture is only for reference and could not match exactly the model you purchased.

WIRE GRILL: it is used as a support to trays, food rings and all the recipients other than the included dripping-pan, or to cook mainly in the Grill and Grill with Ventilation modes (grilling meat and fish, toasting bread, etc.).

DRIPPING-PAN: it is used to collect sauce from the grills or to directly cook foods; if not used, the dripping-pan shall be removed from oven during the cooking phase.

SLIDER BRACKET : For cooking larger size food, these shelf support rails on the right and left sides of the oven can be removed, dishes and tray can be put on the oven floor, using functions as Radiant grilling, Double grilling, Double grill with fan. NOTE: When placing dishes on the oven floor, please DO NOT use functions with bottom heater to prevent heat gathering at bottom.

The oven accessories which may touch the food are made with proper materials according to the applicable laws.

Only use original accessories. They have been specifically designed for you appliance; you can purchase them in our authorized Support Centers.

Note

The heat may cause accessory deformations. This does not affect their usage: once cooled down, they take their original shape.

Plugging in accessories

The oven cavity has five positions. These positions are numbered from bottom to top. ATTENTION: do not use any cooking function placing the food directly (with or without a container) on the oven bottom, but always use the numbered positions.

Note

1. Always insert accessories inside the oven cavity in their right position.
2. Always insert completely accessories inside the oven cavity, so that they don't touch the glass of the oven door.

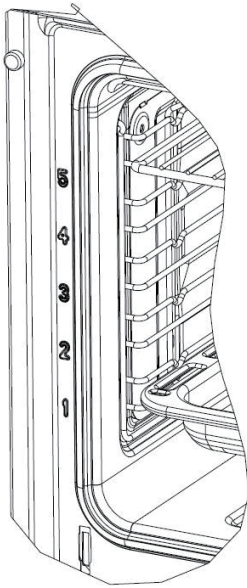

These pictures show the COOKING LAYERS numbered on the front part of the oven cavity, both with side wire frames (on the left), and with soft rails (on the right).

The cooking tables describes the ideal positions for each type of oven use.

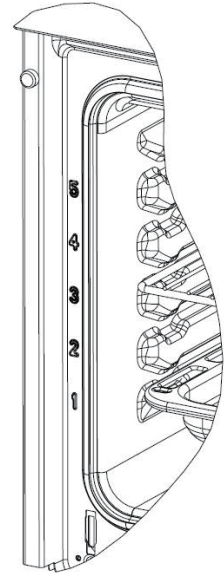

REMOVAL OF WIRE FRAMES (if available)

N.B. The side frames shall be always removed during PYROLYSIS cycle (if available) to prevent damages and discoloration of components.

The following procedure describes the removal of wire side frames. They can be removed to grant the best cleaning of oven, side frames or for defrosting of big food quantity:

1. Remove the accessories inside the oven (Wire grill and dripping-pan).
2. Loose the screw (a) in the bottom part of the side frame (d) under the cooking layers.
3. Lift the side frame towards the top part of the cavity (b).
4. Remove the frame from the holes in the top of the cavity, avoiding damages to the coating.
5. Apply the same procedure to remove the opposite frame.
6. Clean the oven cavity and the side frames with warm water and a soft cleaner (not abrasive), then dry everything.

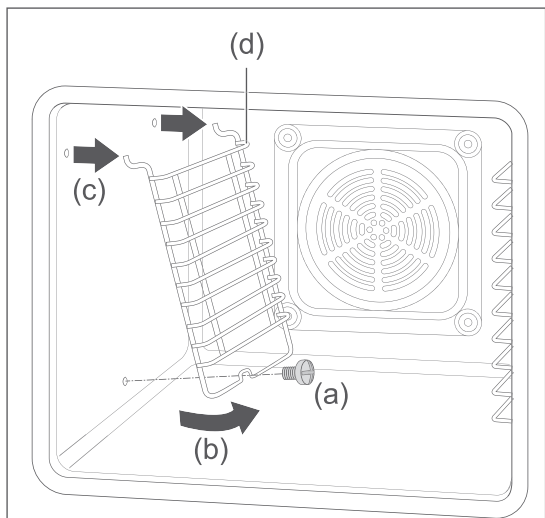

PLUGGING SIDE FRAMES INTO THE OVEN CAVITY

1. Lift the side frame (d), insert the top hooks in their holes on the top part of the cavity edge (c) and rotate it towards the wall.
2. Fix the side frame to the cavity with screw (a)
3. Apply the same procedure to the opposite frame.
4. Now you can plug the dripping-pan and the wire grill inside the cavity.

REMOVAL OF OVEN DOOR

Attention!

Hazard of damages and injuries!!

The oven door is provided with glass panels that may be broken if not properly handled. The broken glass may cause cuts and injuries.

- Don't drop the oven door and the glass panels.
- If a glass is damaged, do not use the oven and contact the Support Center.
- If a glass panel is broken, keep children away and carefully remove all pieces of glass.
- Attention: the oven door may close automatically when trying to remove the internal glasses before removing the door from the appliance.
- Do not use the equipment without internal glasses.

INSTALLATION AND REMOVAL OF THE OVEN DOOR FROM THE APPLIANCE

To clean easily and safely the oven door, it must be removed from the product frame:

1. Wide open the oven door.
2. Open the two locking levers to the left and right outwards (a) as shown on the side (Fig.1).
3. Slowly close the oven door until it stops.
4. With your hands, grab the door on the sides lift it slightly upwards and remove it (Fig.2).
5. Clean the oven door and the various glass panels (see next section for disassembly of the internal glass).
6. Once cleaned, reassemble the oven door on the appliance by performing the reverse procedure, then first make sure that the hinges are inserted in the right position on the right and left. You must be able to insert them easily and without resistance. If you feel any resistance, check that the hinges are inserted correctly in the respective seats.
7. After closing the locking levers to the right and left by pushing them inwards as shown in Fig.3, if the oven door is mounted correctly you can close it without any problem; in addition to closing it correctly if the oven door is mounted correctly it must leave the ventilation slots between the door glass and control panel free.

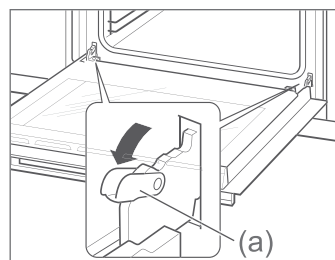

Fig.1

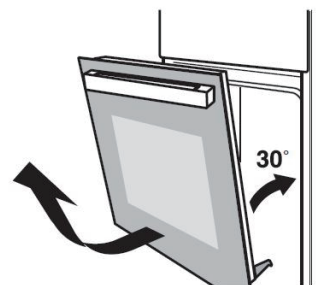

Fig. 2

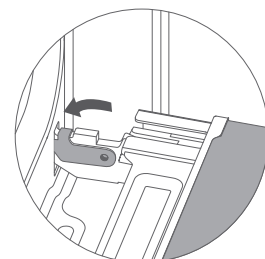

Fig.3

REMOVAL AND CLEANING OF INTERNAL GLASSES FROM OVEN DOOR

The oven door in addition to the double glass or inner glass may contain in some models an additional glass called the third glass and interposed between the double glass and the outer glass. In this section you will be shown how to proceed with the removal of the inner glass that should be cleaned occasionally on both sides.

After removing the oven door from the appliance as described in the previous paragraph, place it on a flat surface (inserting a soft cloth) with the inner glass facing itself.

At this point follow the procedure according to the oven model you purchased.

**For MODELS: MKO 82/12 M BK; MKO 802/12 PR MS XS; MKO 802/12 PR MS BK;
MKO 82/12 MS XS**

A. Push the double glass (inner glass) with two hands in the direction of the hinges.



Figure 1

B. On both sides press with one finger the rear "clamp" (b) forward so as to detach the double glass (a) from the locking brackets fixed to the oven door uprights.

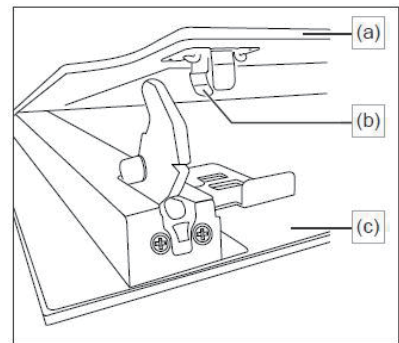

Figure 2

C. Push the double glass (inner glass) as indicated by the arrow in Figure 3 so as to "release" it at the top of the door. You can now remove it.

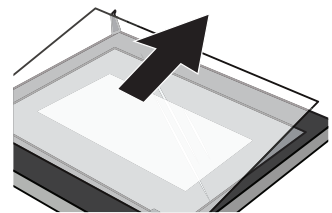

Figure 3

D. After removing the double glass, it is possible to access the third glass (if present) and disassemble it as shown in Figure 4.

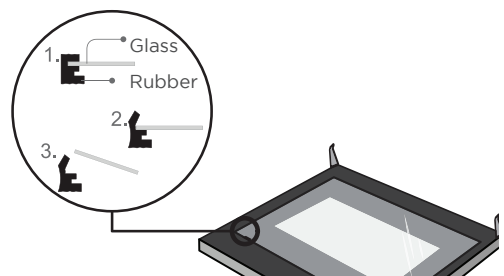

Figure 4

After thoroughly cleaning the glasses with hot water and a soft cloth, dry them thoroughly and reassemble them following the reverse procedure.

Caution, when mounting the double glass (internal glass) make sure that the locking pins positioned at the bottom insert and fit correctly in the relative brackets fixed to the oven door uprights.

At this point it is possible to reassemble the door of the appliance following the instructions described in the previous paragraph.

**For MODELS: MKO 902-PR MS XS; MKO 902-PR M BK;
MKO 902-PR M WH; MKO 906-PR M XS; MKO 1006-PR M P XS**

1. Rotate the two black block stops positioned at the bottom of the oven door as shown in Figure 1

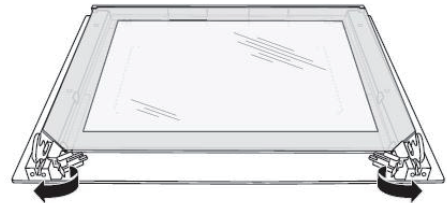

Figure 1

2. Lift the inner glass panel (double glass) at the bottom and carefully push it in the direction of the arrow as shown in Figure 2 and remove it completely from the oven door.

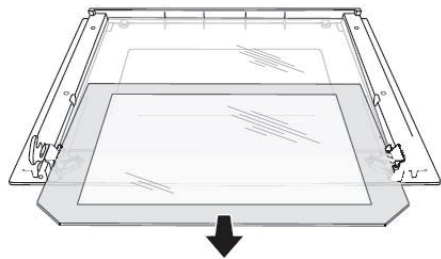

Figure 2

3. At this point, it is possible to remove the intermediate glass (or third glass), first lift it in the lower part (taking care not to lose the rubbers mounted in the two lower corners) and then carefully remove it in the direction of the arrow (Figure 3)

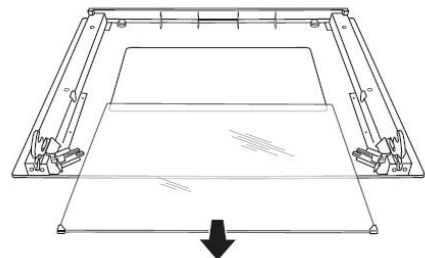

Figure 3

After thoroughly cleaning the glasses with hot water and a soft cloth, dry them thoroughly and reassemble them following the reverse procedure.

At this point it is possible to reassemble the door of the appliance following the instructions described in the previous paragraph.

LAMP REPLACEMENT

If the lamp on the rear wall of the oven compartment lightens up, it must be replaced. Heat resistant halogen lamps are available from the Service Centre or specialist retailers (230 V~, 25 W, G9, T 300°C).

When handling the halogen lamp, use a dry piece. It will increase the lamp's life cycle.

WARNING

Electric Shock Hazard!

When replacing the lamp, the connector contacts are live. Before replacing the lamp, remove the power outlet from the appliance or disconnect the jump switch from the meter.

Risk of burns!

The appliance becomes very hot during operation. Never touch the inside surfaces of the appliance or the heating elements when it is still hot. Always let the appliance cool. Keep children at a safe distance.

1. Place a cloth on the bottom of the oven, which must be cold, to prevent damage.
2. Turn the glass cover counterclockwise to remove it.
3. Remove the lamp. WARNING, pull the LAMP DO NOT rotate it.
4. Insert the new lamp, making sure that the pins are in the correct position.
5. Refit the glass cover.
6. Remove the cloth from the bottom of the cavity, reconnect the power supply and select LIGHT function to see if the lamp turns on.

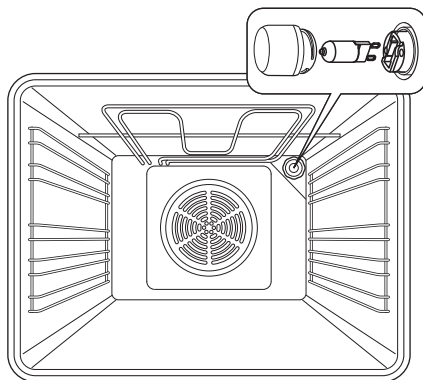

Glass cover

If the glass cover of the halogen lamp is damaged, it must be replaced.

You can find the glass cover at the service desk. Please specify the model and serial number of your appliance.

POWER CABLE REPLACEMENT

Instructions for correct cable replacement:

- a) After unplugging the plug from the socket, use a small flat screwdriver to open the terminal block in steps 1 and 2.
- b) Use the star screwdriver to remove the screws 3, 4, 5 and 6.
- c) Replace the power cord with the new one and secure the yellow/green wire in point 3, the brown wire in point 4 and the blue wire in point 5.
- d) To complete the operation tighten the screw of point 6 and close the terminal block.

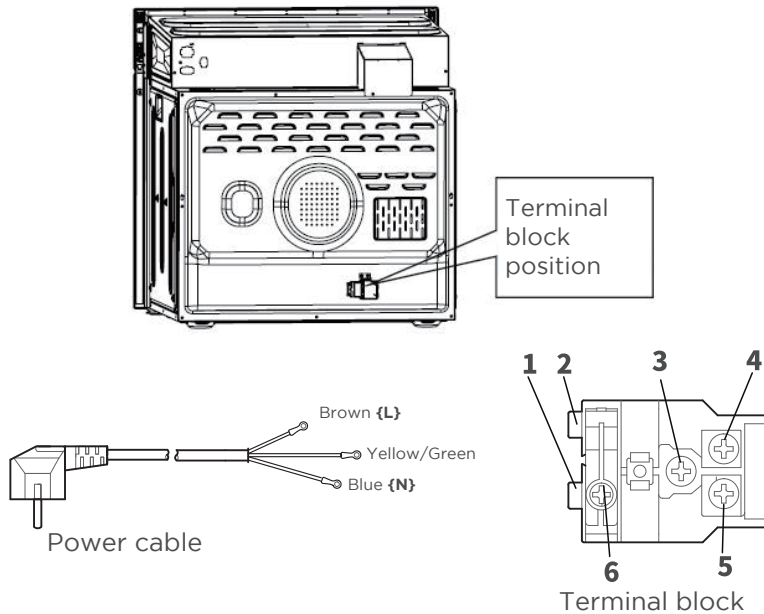

Caution, risk of electric shock!

Improper servicing could be dangerous. Repairs can be made and damaged cables replaced only by specialist service technicians. If the appliance is faulty, remove the cord from the power outlet or disconnect the jump switch from the meter. Contact customer support.

Attention!

The oven could be supplied with cord without plug (for the characteristics of the plug and the electrical connection see the appropriate section).

GENERAL ENERGY SAVING INDICATIONS

1. Remove all unnecessary accessories during the cooking and baking process
2. Do not open the oven door during cooking and baking
3. If you open the oven door during cooking and baking, turn on the "Light" mode (without changing the temperature setting)
4. Reduce the temperature in unventilated mode to 50°C from 5 to 10min before the end of cooking and baking time. This way, you can use the heat of the oven compartment to complete the process
5. Use the fan when possible. You can reduce the temperature from 20°C to 30°C
6. You can cook and bake on more than one level at a time using the ventilated static cooking function or conventional cooking (if present).
7. Use the residual heat inside the oven after a cooking is completed to heat other foods.
8. Do not preheat the empty oven, if not necessary. If preheating is necessary, put the food in the oven immediately after it has reached the temperature indicated by the light switch off
9. Do not use reflective aluminium foil to cover the bottom of the oven compartment
10. Use moulds and containers with a dark opaque coating and light weight. Try not to use heavy accessories with shiny surfaces, such as stainless steel or aluminium.

ENVIRONMENT

Packaging is made to protect your new appliance from damage during transport. The materials used are carefully chosen and must be recycled. Recycling reduces the use of raw materials and waste. Electrical and electronic equipment often contains useful materials. Please do not dispose of it with your household waste.



HEALTH

Acrylamide is produced primarily by heating starchy food (e.g. potatoes, fries, bread) at very high temperatures for a long time.

Suggestions

1. Use short cooking times.
2. Cook the food to a golden surface colour, do not burn it to a dark brown.
3. Larger portions have less acrylamide.
4. Use a fan cooking mode.
5. Baked fries: use more than 450 g per baking sheet, spread evenly and turn occasionally. Use the product information if available to get the best cooking result.

CLEANING AND MAINTENANCE OF YOUR APPLIANCE

Detergents

With good maintenance and cleaning, your appliance will maintain its appearance and remain fully functional for many years to come. Below are some instructions for cleaning and properly maintaining your appliance.

Make sure that the different surfaces are not damaged using the wrong detergents, follow the information in the table. Depending on the model of appliance, not all areas listed may be present.

Attention!

Risk of damage to surfaces

Do not use:

1. Strong and abrasive detergents or detergents containing soda, ammonia, acids and chlorides
2. Products containing solvents.
3. Stainless steel brushes or straws or sponges that still contain abrasive substances.
4. Oven spray, glass or dishwasher detergents.
5. Special cleaners to clean the appliance when it is hot.

Before first use, thoroughly clean the oven with a new sponge.

Tip

It is strongly recommended to purchase cleaning and care products through the service desk and to follow the manufacturer's instructions and suggestions.

Exterior area of the appliance	Cleaning
Stainless steel control panel cover (if present)	<p>Hot soapy water: Clean with a towel and then dry with a soft cloth.</p> <p>Remove traces of anti-limescale, fat, starch and albumin (e.g. egg white) immediately as corrosion may occur under these traces.</p> <p>Special stainless steel cleaning products suitable for hot surfaces are available from our service desk or specialist retailers. Apply a very thin layer of detergent with a soft cloth.</p>
Plastic	<p>Hot soapy water: Clean with a towel and then dry with a soft cloth. Do not use glass products or scrapers.</p>
Enamelled surfaces (oven interior)	<p>Hot soapy water: Clean with a towel and then dry with a soft cloth.</p>
Control panel	<p>Hot soapy water: Clean with a towel and then dry with a soft cloth. Do not use glass products or scrapers.</p>
Oven door glass	<p>Hot soapy water: Clean with a towel and then dry with a soft cloth. Do not use steel scrapers or flakes.</p>
Oven door handle	<p>Hot soapy water: Clean with a towel and then dry with a soft cloth.</p> <p>If the limescale remover comes into contact with the door handle, clean immediately. Otherwise, any stains can no longer be removed.</p>
Glass cover for indoor lighting	<p>Hot soapy water: Clean with a towel and then dry with a soft cloth.</p>
Oven seal (do not remove)	<p>Hot soapy water: Clean with a sponge. Do not rub.</p>
Stainless steel oven door cover (if present)	<p>Hot soapy water: Clean with a towel and then dry with a soft cloth.</p> <p>Remove traces of anti-limescale, fat, starch and albumin (e.g. egg white) immediately as corrosion may occur under these traces.</p> <p>Special stainless steel cleaning products suitable for hot surfaces are available from our service desk or specialist retailers. Apply a very thin layer of detergent with a soft cloth.</p>
Interior accessories (Drip pan/Metal grill and wire side frames)	<p>Hot soapy water: Wet thoroughly and wipe with a sponge or soft damp cloth. Only use neutral detergents, do not use abrasive products, abrasive sponges, solvents or metal objects.</p> <p>Do not wash in the dishwasher.</p>

Exterior area of the appliance	Cleaning
Telescopic guides (if any)	<p>Hot soapy water: Clean with a cloth or sponge. Do not wash in the dishwasher. It is advisable to clean the guides when they are closed inside the oven to avoid removing the lubricant necessary for proper sliding.</p>
Meat probe (if present)	<p>Hot soapy water: Clean with a sponge or soft cloth. Do not wash in the dishwasher.</p>

Note

1. The slight differences on the front of the appliance are due to the use of different materials, such as glass, plastic and metal.
2. The shadows on the oven door panels, which look like streaks, are caused by the reflections created by the interior lighting.
3. The enamel is baked at very high temperatures. This may cause some slight variation in colour. This is normal and does not affect how it works. The edges of thin baking trays cannot be completely enamelled and can therefore be sharp. This does not compromise corrosion protection.
4. Always keep the electrical appliance clean and remove any dirt right away to avoid accumulation.

Suggestions

1. Clean the cooking compartment and its accessories after each use and let them dry thoroughly. Use a damp cloth with warm soapy water.
2. Remove traces of limestone, fat, starch and albumin (e.g. egg white) immediately after use.
3. Remove traces of food containing sugar immediately after use, if possible, when the residue is still hot.
4. Regularly check the oven seal and its cleaning (located between the cavity and oven holder is located around the cavity frame). To clean the gasket, please refer to the information in the table above. Do not use the oven if the gasket is damaged, contact the Authorized Service centre.

TROUBLESHOOTING

If a defect occurs, before calling the service desk, make sure that it is not due to incorrect operations by consulting the following defect table.

Defect	Defect Possible cause	Notes/solution
The appliance does not work	Faulty fuse.	Check the meter jump switch.
	Blackout	Check that the kitchen light or other appliances in the kitchen are working.
The knobs (if any) have been removed from the respective rod	The knobs were accidentally disengaged.	Simply insert the knobs into the respective rods placed in the control panel and press them so that they snap together and can be rotated normally.
The knobs (if any) cannot be easily rotated.	There may be dirt under the knobs.	<p>The knobs can be removed for cleaning. To remove the knobs, simply remove them from the respective rod by pulling them towards themselves.</p> <p>Carefully clean the knobs using a cloth and soapy water. Dry thoroughly, using a soft cloth. Do not use sharp or abrasive materials. Do not wet or wash in the dishwasher. Do not remove the knobs too often so that the coupling with its rod does not become too loose.</p>

Defect	Notes/solution
After a cooking process you can hear a noise and you can notice an air leak between the oven door and the control panel.	The cooling fan continues to work even when the oven is turned off for a few minutes, to avoid high humidity conditions inside the oven and cool it. The cooling fan will turn off automatically.
The food is not completely cooked in the time indicated by the recipe.	A temperature different from that indicated in the recipe has been used; check if the set temperature corresponds to that indicated by the recipe. The amount of ingredients used is different from that indicated in the recipe; please check the recipe again and the relative quantities of ingredients.
Non-uniform gilding	The set temperature is too high, or the cooking level must be optimized; check the recipe and settings. The pan chosen for the selected cooking function was not great for size and/or colour and/or material. When using radiant heat (“Traditional cooking”), use pyrophyll with a matt finish, dark colours and light weight.

CUSTOMER CARE

Our service desk is ready to help you solve any type of problem with your appliance. We will always find a solution. Please contact the supplier from whom you purchased your appliance. When you call us, please provide model and S/N (serial number), so that we can advise you properly. The plate bearing these numbers can be found on the facade of the oven, visible when you open the door.

Example:

Model	MKO 902-PR M WH
Recommended voltage:	220-240 V~
Recommended frequency:	50 Hz-60 Hz
Electric Power:	3.0 kW



To save time, please note the model of your appliance and the help desk phone number in the space below, if necessary.

MAINTENANCE SHEET

Model No.	Date of purchase
Serial number	Shop where purchased

Attention

This appliance must be installed in accordance with current regulations and used only in a well-ventilated space. Read the instructions before installing or using the appliance.

Note

Please note that the home visit of a technician from our service centres is not free, even if contacted during the warranty period.

If you decide to rely on a certified professional, you will be sure that the repair will be carried out by technicians who will bring the original spare parts for your appliance.







Thank you again for purchasing a Master-Kitchen built-in oven and we hope that your appliance will give you delicious dishes and great satisfaction in the kitchen.

GENERAL STATEMENTS

Do you want to cook your own recipe	Try to use the settings of a similar recipe and optimize the cooking process based on the result.
Is the cake ready?	Stick a stick into the cake about 10 minutes before the cooking time is over. If there is no dough attached to the stick when you parade it, the cake is ready.
Cake loses volume as it cools after cooking	Lower the set temperature by 10°C and recheck the instructions for the preparation of the dough.
The cake is higher in the centre than the edge	Do not grease the outer ring of the cake pan
The cake is too dark at the top	Use a lower cooking level and/or use a lower temperature (this may result in a longer cooking time)
The cake is too dry	Increase the set temperature by 10°C (this may result in a shorter cooking time)
The food looks good but the humidity inside it is too high	Lower the set temperature by 10°C (this may result in a longer cooking time) and recheck the recipe.
The goldness is no uniform	Lower the set temperature by 10°C (this may result in a longer cooking time). Use the "Traditional cooking" function on a single level.
The cake is less golden on the bottom	Use a lower cooking level
Cooking on two levels: foods are darker on one of the two levels	Use a fan function to cook on two levels and pull out the pans individually when they are ready. It is not necessary that all trays are ready at the same time.
Condensate water vapour during cooking	This is a normal physical event, during the cooking phase a lot of water vapour can form in the cooking compartment. The appliance has a high energy efficiency and only a small amount of heat emanates from the outside during operation. Due to the high temperature differences between the inside and outside of the appliance condensation may be deposited on the door, control panel or panels of nearby furniture. With preheating, or by opening the oven door with caution, condensation can be reduced.
What kind of trays can be used?	Any heat-resistant cake pan can be used. Aluminium should not be used in direct contact with food.
How to use the grill function.	Preheat the oven for 5 minutes after which place the food at the level indicated by the recipe (refer to the table for typical recipes). Close the oven door when using any grill cooking mode. Do not use the oven when the door is open, except to load, remove or control food.







How to keep the oven clean when cooking with grill.	Use the supplied drip pan filled with 2 litres of water by placing it at level 1. Almost all fluids from the food on the grill will be captured by the pan.
The heating element in all grilling modes turns on and off continuously.	It is a normal operation and depends on the temperature settings.
How to calculate oven settings when the weight of a roast is not given by a recipe?	Choose settings close to the roast weight and slightly change the time. Use meat probe (if available) to detect internal meat temperature.

FOOD QUALITY GRADE: COMPLIANT TO EN 60350-1



DISH	COOKING LEVEL	FUNCTION	TEMPERATURE in °C	COOKING TIME in min.
Pastafrolla biscuits	4		150-170	20-30
Sponge cake (with water)	2		170-180	25-35
Apple tart	4		180-190	35-45
Apple tart	4		180-190	15-25
Toast	3		250	1-3
Meat Burger	4		250	12 then turn and continue for 8-12
Pizza	3		190-210	15-25

N.B. For all recipes in the table above, always preheat the oven for 5 - 15 minutes regardless of the other cooking instructions.

OTHER TYPICAL RECIPES

DISH	COOKING LEVEL	FUNCTION	TEMPERATURE in °C	COOKING TIME in min.
Muffins	1 or 2		150-170	20-30
Beef fillet (about 1.6 kg)	2		170-180	25-35
Chicken about 1 Kg	2		180-190	35-45
White Bread (1 Kg of Flour)	1		180-190	15-25
Cheese-Cake (cake pan diameter 20 cm)	2		250	1-3
Fish about 2.5 Kg	2		250	12 then turn and continue for 8-12
Roasted pork neck	1		160	85



OTHER TYPICAL RECIPES

DISH	COOKING LEVEL	FUNCTION	TEMPERATURE in °C	COOKING TIME in min.
Baked fries (1 Kg)	2		200	30
Stuffed Tomatoes	3		180	12

N.B. For all recipes in the table above, always preheat the oven for 8 - 15 minutes regardless of the other cooking instructions.

ATTENTION, not all the cooking functions mentioned in the tables may be present in the appliance you purchased

COOKING IN GREEN MODE

DISH	COOKING LEVEL	FUNCTION	TEMPERATURE in °C	COOKING TIME in min.
Potato and Cheese Gratin	1		180	90-100
Cheese Cake	1		160	100-150
Meat balls	1		190	110-130

N.B. Oven preheating is not required for all recipes in ECO mode.

ENERGY SAVING: COMPLIANT TO EN 60350-1

Please note the following information:

1. Measurement shall be carried out IN ECHO mode to determine the forced air mode and label class data
2. The measurement is carried out in "Traditional cooking" mode to determine the data concerning the traditional cooking mode
3. During the measurement, only the necessary accessory is in the oven compartment. All other parts must be removed
4. The oven is installed as described in the installation guide and positioned in the centre of the built-in cabinet
5. For the measurement, it is necessary to close the door as at home, even when the cable disturbs the sealing function of the seal during the measurement. To ensure that there are no adverse effects regarding the sealing disturbed due to energy data, it is necessary to close the door carefully during measurement. It may be necessary to use an instrument to guarantee sealing of the gasket as at home, where no cable disturbs the sealing function.
6. The volume of the oven compartment was determined to use thawing as described on page 22. To ensure effective oven use, all accessories that include the side grills must be removed.

DATA SHEET (EU 65/2014 & EU 66/2014)

Model MKO 82/12-M BK MKO 82/12 MS XS	
No. of compartments	1
Heat source	Electric
Usable volume	65 L
ECElectric, compartment (conventional)	0.99 kWh/cycle
ECElectric, compartment (forced air)	0.77 kWh/cycle
EIECavity	94
Energy class (A+++ to D)	A

DATA SHEET (EU 65/2014 & EU 66/2014)

Model MKO 802/12-PR MS XS Model MKO 802/12-PR MS BK Model MKO 902-PR M XS Model MKO 902-PR M BK Model MKO 902-PR M WH Model MKO 906-PR M XS Model MKO 1006-PR M P XS	
No. of compartments	1
Heat source	Electric
Usable volume	70 L
ECElectric, compartment (conventional)	0.99 kWh/cycle
ECElectric, compartment (forced air)	0.79 kWh/cycle
EIECavity	94
Energy class (A+++ to D)	A



Master Kitchen
Midea Italia srl
Made in P.R.C.

